

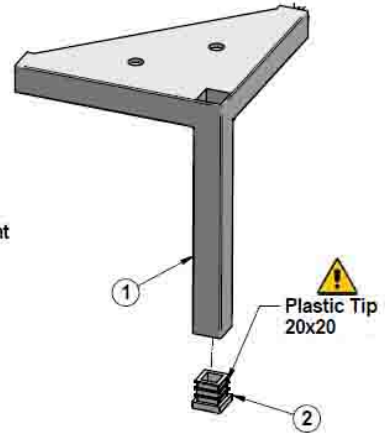

PART #	MATERIAL	FINISH	HEIGHT	PACK SIZE
20FFOGNS170S	IRON	NICKEL SATIN	6.7" (170MM)	48PCS

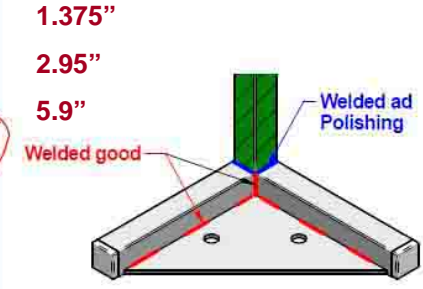
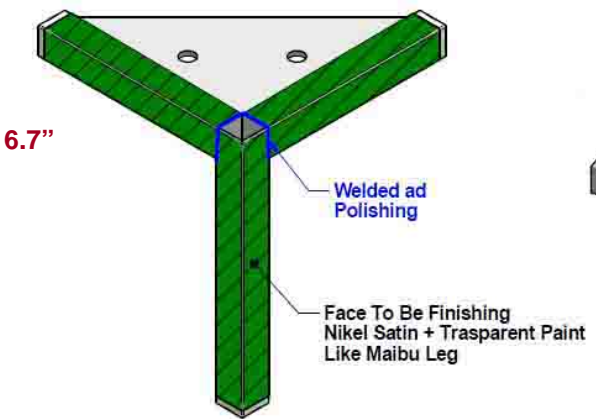
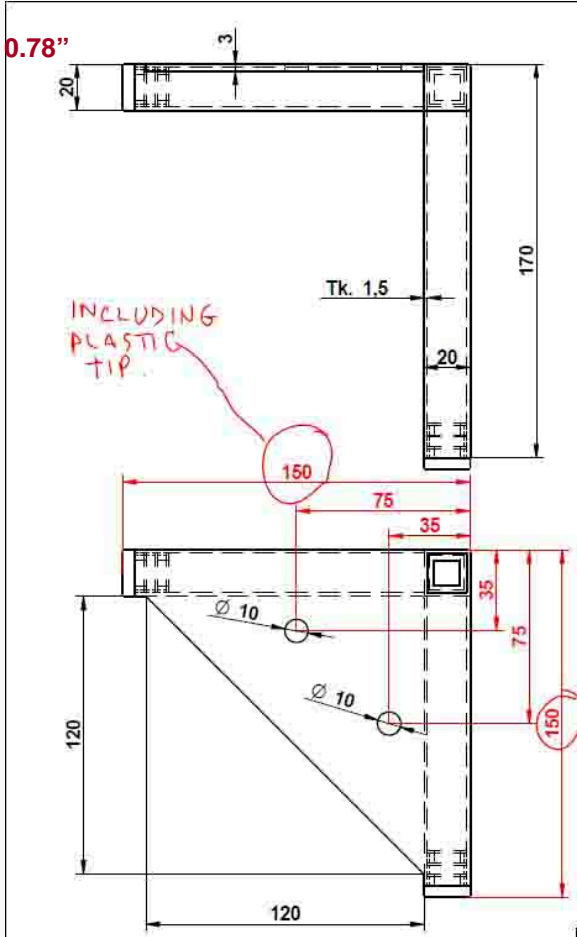

Pos	Description	Pz	Material	KG	Cod.	Finishing
2	Plastic Tip 20x20	3	Plastic			Transparent
1	Tubular 20x20 TK 1,5	1	Iron			NICK/SAT

Remove any bevel and/or residual material and/or sharp edges

Rev	Data	Modifica	Firma	Controllato
01	13/07/10	Change quote in red	Fabio	Riccardo
00	1/07/10	Editing Draw	Fabio	Riccardo

IRON S.p.A. di
 Milano in direzione
 del presidente
 e amministratore
 delegato
 P.O.A. S.p.A. di
 Milano in direzione
 del presidente
 e amministratore
 delegato

**Iron Leg "Fogo" 150x150 H170mm
 Fin.NICK/SAT Rev.01**

Art. Code: **20FFOGO170S**
 Reference: **(EX RS...)**

Formato foglio: -
 Scala: -

Dimensioni & Angoli non allowed - UNI ISO 22765 1 - 2
 Mechanical Processes: Class 1 (Capacities) Class 10

Signature & Print of approval

Massa
0,500 kg

FINISHING	Nikel Satinized + Trasparent Painting (Like Maibu Leg)
BEVEL	Required on sharp parts
FACES TO BE FINISHED	All
ASSEMBLING	Complete -plastic tip included-
PACKAGING	Single Pluriball Bags with Salts + Carton Box
	Standard 324

LEGEND
 80 = measurement in millimeters
 4" = measurement in inches